

AccuCell



Power Measurement Method



SIMUCAD



Power Concept and Definitions

- **Static Power:**
 - Constant power dissipated by the cell in steady state after the vector is applied and all transitions are stabilized.
 - Sub-threshold leakage from source to drain;
 - Current flow through reverse biased diode (diffusion layer and substrate).
 - Less than 1% to >30% of total power when cell active but the majority of power when cell inactive
- **Dynamic Power:**
 - Power dissipated when an input transition is being made.
 - charging/discharging internal and external capacitive loads;
 - Short circuit current from VDD to GND due to all transistors on or partially on.



Power In Synopsys .LIB Format

- Leakage Power:
 - The same as static power;
- Internal Power:
 - Dynamic power dissipated within the cell boundary:
 - Short circuit current from VDD to GND;
 - Charging and discharging internal nodes.
 - Hidden Power – Inputs switching power when outputs not switching
- Synopsys .LIB format
 - models only the leakage and internal power
 - Leakage power: A single number per cell or cell state. (in the unit of “power”: e.g: nW)
 - Internal power: a lookup table. (in the unit of “energy”: e.g:pJ)



Switching Power on Output Load

- Switching power:
 - Dynamic power dissipated when charging and discharging the load capacitance at the output pin;
 - 70-90% of the total power consumption in a CMOS circuit;
 - Synopsys PowerCompiler calculates it for a given cap load and toggling rate on the output pin.
- AccuCell reports it in its log file:
 - A look up table format just like internal power.



Hidden Power

- Hidden power is the power dissipated when there is clocking/ switching activity on the cell inputs and the output is not changing
- Hidden power analysis is automatically activate if the cell is a sequential cell when power config commands are enabled
- Hidden power analysis will ensure that clock pin power or input pin power and output power are accounted for separately

Power Characterization Model

- AccuCell uses the following circuit configuration for power characterization:

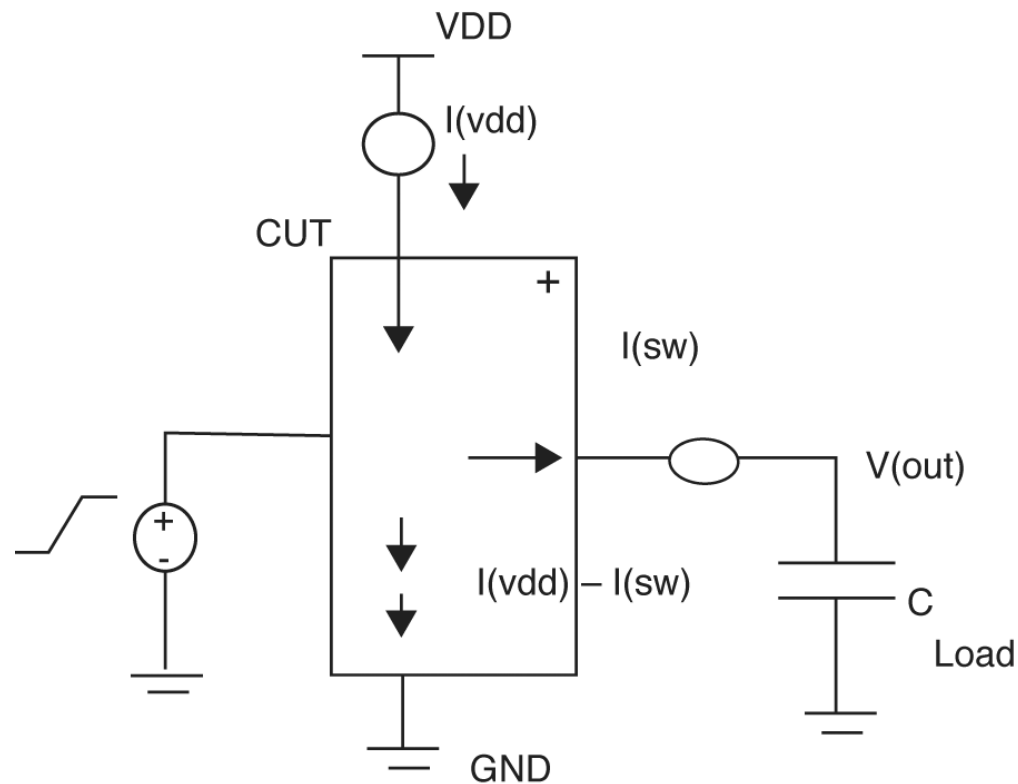



Internal Power Characterization

- The total power, or energy, can be calculated as:

$$E(\text{total}) = \int_{T1}^{T2} V_{\text{dd}} * I (V_{\text{dd}}) dt \quad \{\text{Note: measurement window: T2-T1}\}$$

- The avg switching power can be calculated as:

$$E(\text{sw}) = \int_{T1}^{T2} V(\text{out}) I (\text{sw}) dt = \int_0^{V_{\text{dd}}} C_{\text{load}} * V (\text{out}) dv = 1/2 C_{\text{load}} * V_{\text{dd}}^2$$

- The internal power can then be calculated as:

$$E(\text{int}) = E(\text{total}) - E(\text{sw}) = \int_{T1}^{T2} V_{\text{dd}} * I (V_{\text{dd}}) dt - 1/2 C_{\text{load}} * V_{\text{dd}}^2$$

where the current integration can be done by SPICE internal function calls



Current Curve: Measurement Windows

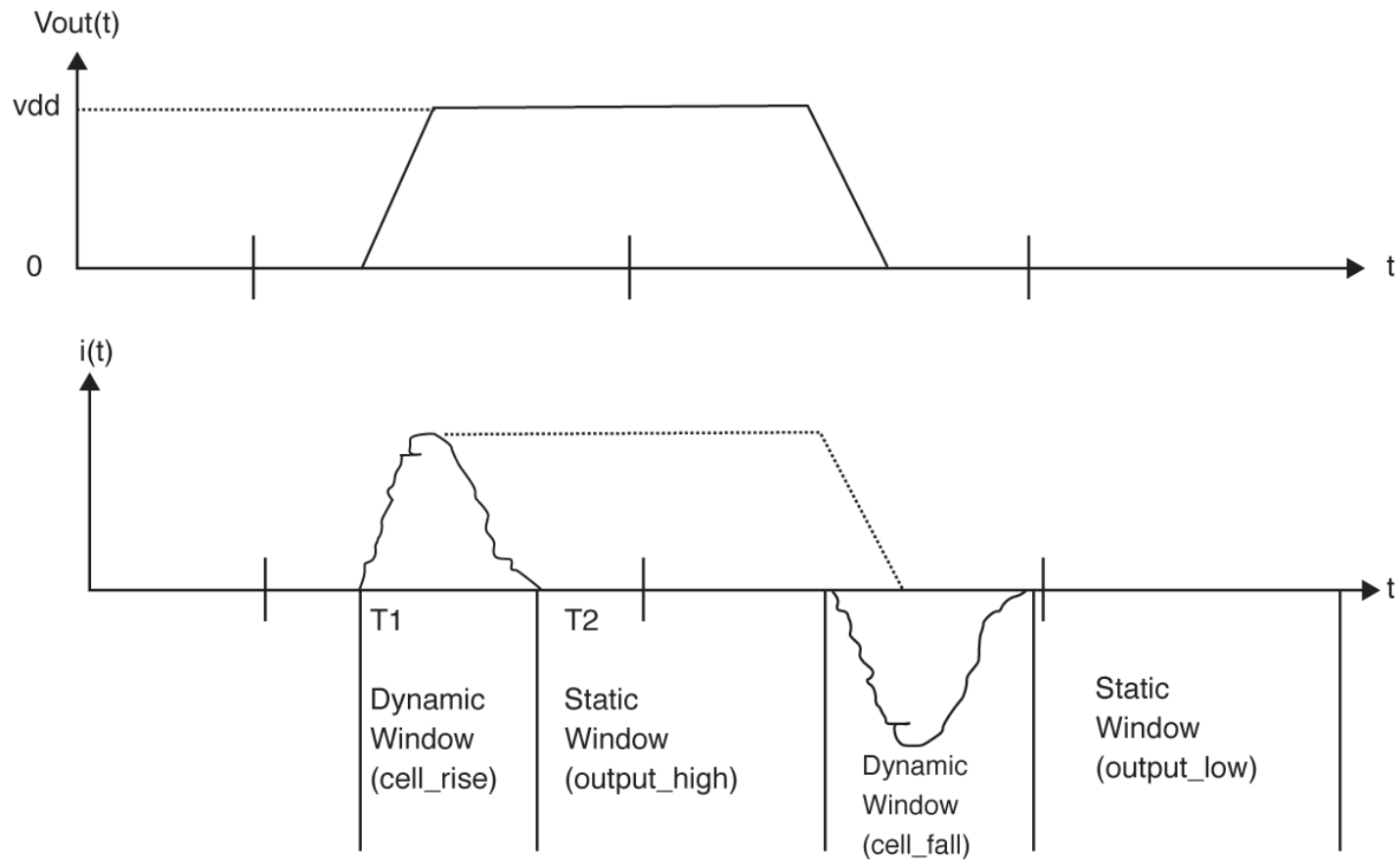



Internal Energy Measurement

- The internal power, or energy, can be calculated for each transition as:

$$E_{int} = E_{total} - E_{sw}$$

In AccuCell above formula is used for EACH rise AND fall transition



Total Energy Measurement

- The total power, or energy, can be calculated (for each transition) as :
{Note: Measurement window: T2-T1}

$$E_{total} = V_{dd} \int_{T1}^{T2} I(V_{dd}) dt = V_{dd} \cdot I_{vdd} \cdot (T2 - T1)$$

In AccuCell, ***Ivdd*** is measured directly from Spice



AccuCell Power Measurement Windows

- The accuracy and runtime for power characterization depends on how $(T2 - T1)$ is determined:
 - Too small: part of dynamic power will fall into leakage power;
 - Too large: vector buffer size so large that runtime increases.
- Two methodologies:
 - Voltage based: 50% to 95% of VDD determines $(T2-T1)$
 - Current due to 10% of transition contributes to leakage power.
 - Current based: Analyze $I(V_{dd})$ curve to determine $(T2-T1)$
- AccuCell Advantage: current based!
 - Curve's nature: Peak, Monotonic, local MINs or MAXs etc.
 - Signal-processing-like technique to filter unwanted numerical noises



Power Measurement Steps in AccuCell

- Initial spice run to determine the measurement windows (T2, T1) for both dynamic and static power
- Second simulation with .measure commands to extract current or power
 - Etot: In AccuCell Ivdd is measured directly from spice
 - $P_{tot} = I(vdd) * V_{dd}$ then $E_{tot} = P_{tot} * (T2 - T1)$
 - Esw: In AccuCell Psw is measured directly from spice
 - $E_{sw} = P_{sw} * (T2 - T1)$
 - $E_{int} = E_{tot} - E_{sw}$



Example: Current Curve

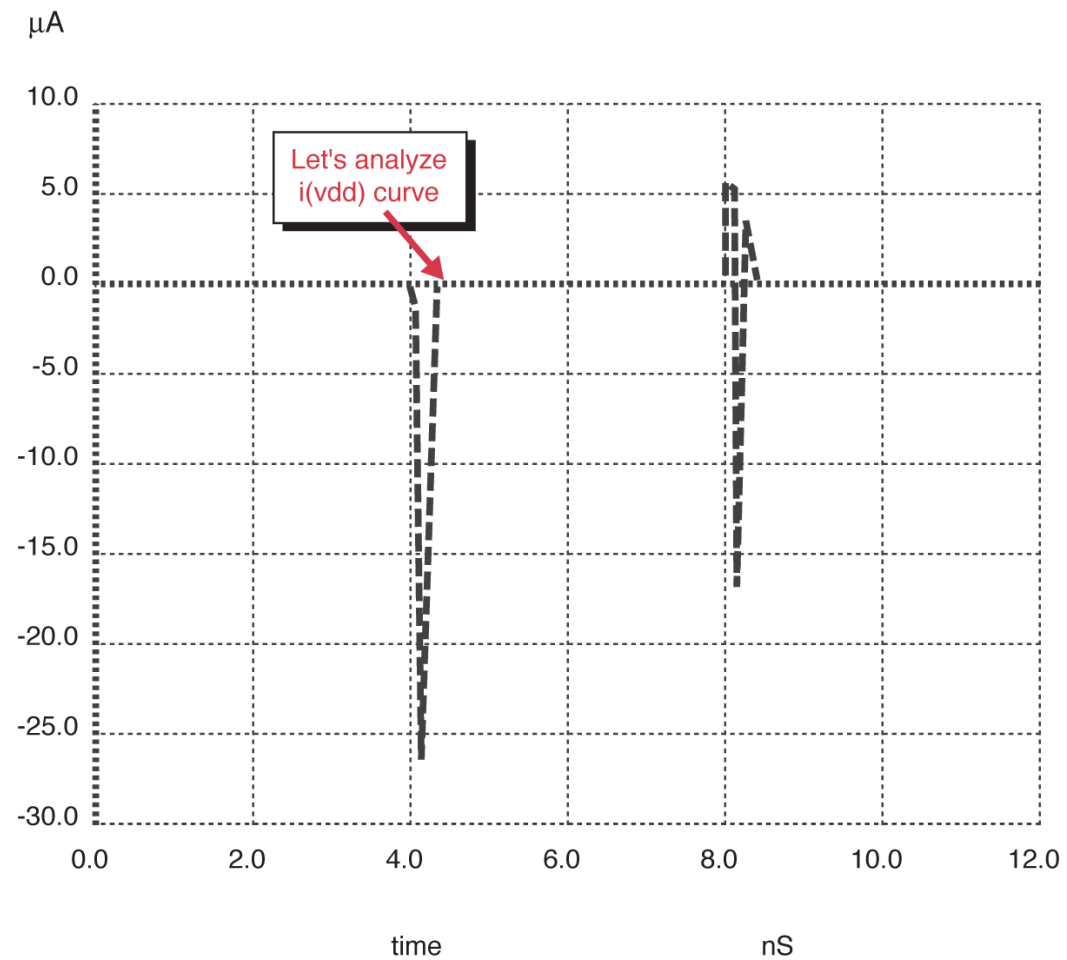



Example: Current Curve

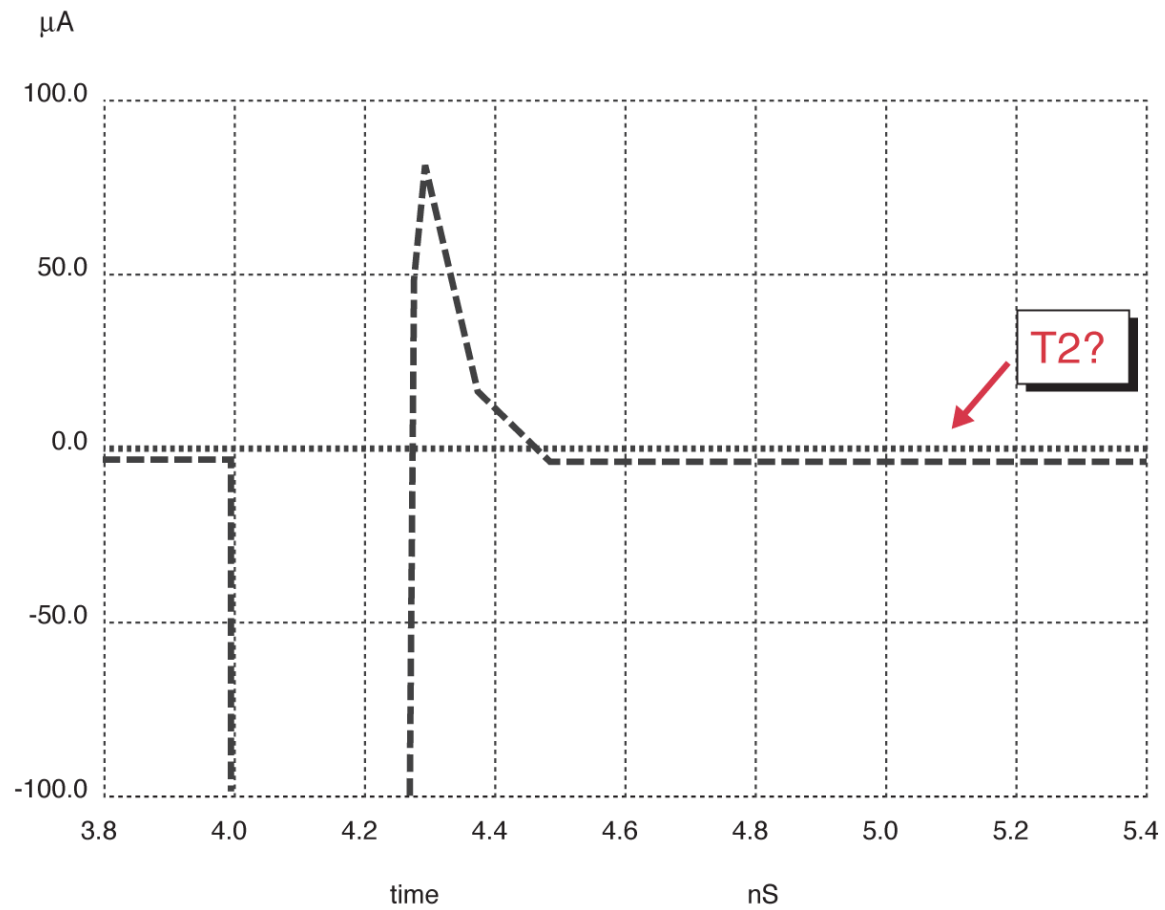



Example: Current Curve

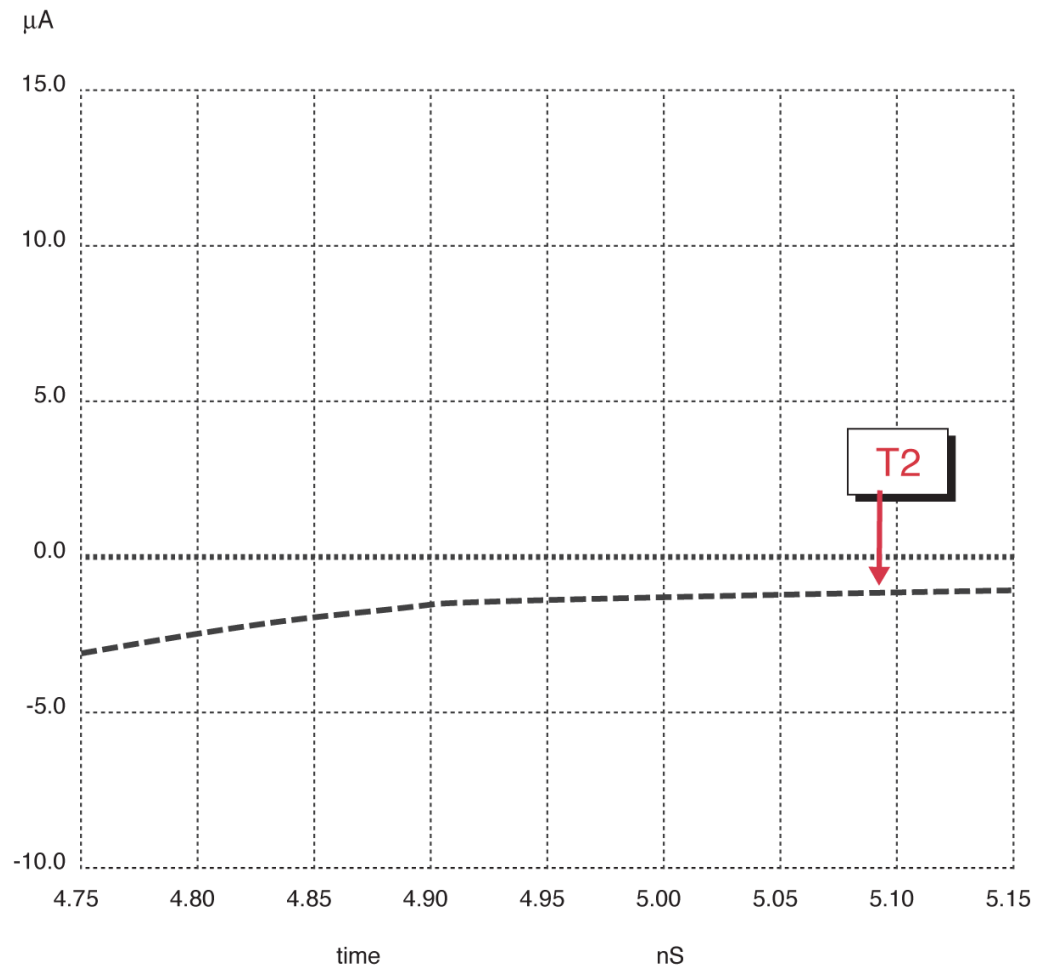



Example: AccuCell Power

- Step 1: SPICE deck to determine T1, T2:

```
:  
.measure tran vout_r_1_0 WHEN v(n5881)=0. 54 TD=0 RISE=LAST  
.measure tran vout_f_1_0 WHEN v(n5881)=0. 54 TD=0 FALL=LAST  
.measure tran vout_r_1_0_vecstr WHEN V(n5881)=0. 54 TD=0 RISE=1  
.measure tran vout_r_1_0_vecstr WHEN V(n5881)=0. 54 TD=0 FALL=1  
:
```

- Step 2: SPICE deck to measure currents:

```
:  
.measure tran i_pwr0_rf0 AVG i(v38475136) FROM=3. 820000e-09  
+ TO=5.104000e-09  
.measure tran i_pwr0_rf2 AVG i(v38475136) FROM=8. 000000e-09  
+ TO=8. 252000e-09  
.measure tran i_pwr0_0 AVG i(v38475136) FROM=0. 0 TO=3. 820000e-09  
.measure tran i_pwr0_1 AVG i(v38475136) FROM=5.104000e-09  
+ TO=8.000000e-09  
:
```

Other Tools Power Measurement

$$E_{int} = E_{Total} - E_{sw}$$

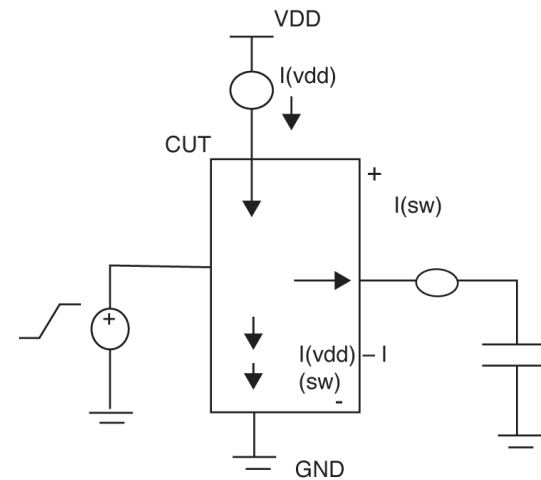
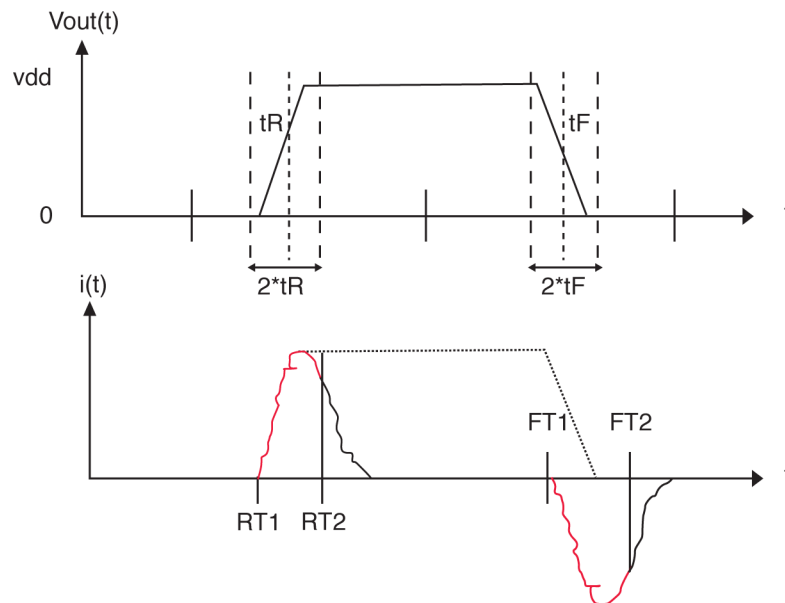

- Dynamic Power Switching range based on output RISE/Fall Time not Cell current behavior (See Red)
- Dynamic Power is always in error on Medium to Large Cells
- Leakage number Calculated in unrealistic conditions



AccuCell: A Summary

$$E_{\text{int}} = E_{\text{Total}} - E_{\text{sw}}$$

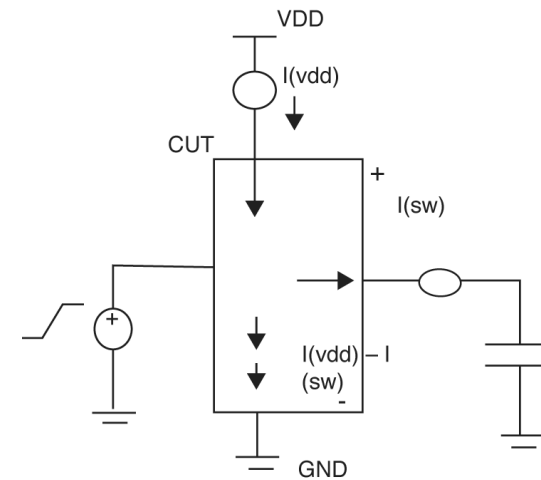
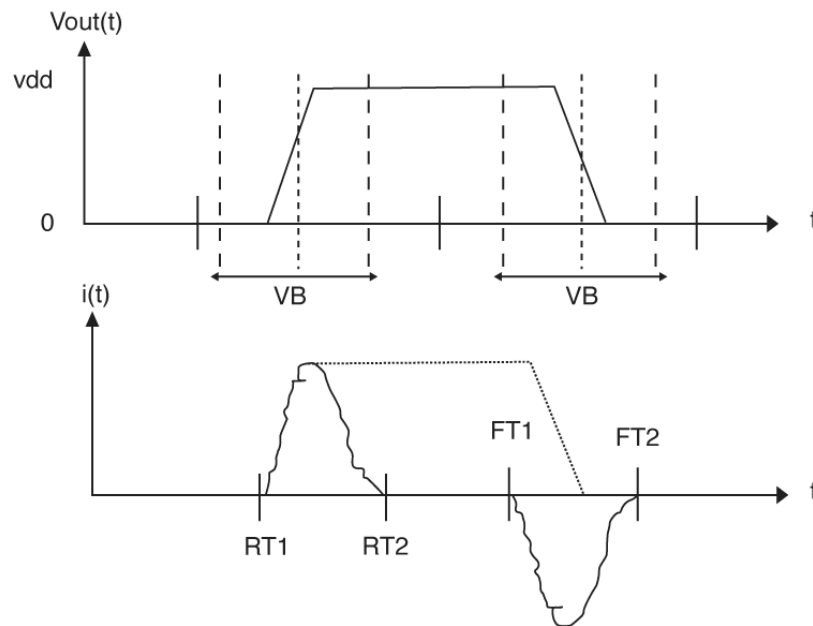

- Technique includes finding the $i(v_{\text{dd}})$ and $P(\text{cap})$ for **BOTH** the rising **AND** falling output transitions
- Integrating the results over time yields the total energy consumed by the cell



Leakage Power Characterization

- Leakage Power measurement:
 - Analyze current curve $I(v_{dd})$ from SPICE simulation;
 - Measure $I(v_{dd})$ DC static state
 - Use the following equation for leakage power:
 $P(\text{leakage}) = V_{dd} * I(V_{dd})$
 - State-Dependent Leakage (vector dependencies)



AccuCell Commands for POWER Characterization

lib.cfg

```
LIBRARY_NAME          lib1
MODEL_TYPE            generic synthesis tlf

#---SPICE COMMANDS

SPICE_TYPE            smartspice
SMARTSPICE_OPTIONS    ACCURATE
MOSFET_TYPE           p pmos
MOSFET_TYPE           n nmos

#---Specify Process File (mosfet model) information

INC_CMD "/home/models/param_file"
LIB_CMD " '/home/models/bsim3v3.1' typ"

#----- CHARACTERIZATION COMMANDS

TEMP                  25
SUPPLY_V_HIGH         5
#SCALE_FACTOR         1.0e-6
TRAN_ANALYSIS_STEP    0.01
```

```
#-----COMMANDS FOR INPUT SLOPES & OUTPUT LOADS

EXTEND_SLOPE         1
SLOPE_LOWER_THR      0.2
SLOPE_UPPER_THR      0.8
SLOPE_TABLE          {0.10 0.2 0.3 0.4}
CAP_TABLE             {0.011 0.022 0.033 0.044 0.055}

#-----COMMANDS for SETUP & HOLD

SETHOLD_METHOD        "internal"
SH_BISECT             1
SETHLD_2D             1
SH_DATA_SLOPE_TABLE  {0.1 0.2 0.3 0.4}
SH_CLK_SLOPE_TABLE   {0.05 0.1 0.5 1.0}

#-----POWER CHARACTERIZATION COMMANDS-----

CHAR_POWER            1
CHAR_POWER_METHOD     average|peak|rms
LEAKAGE_POWER_UNIT    uW
```



What Competitors are Doing?

- Measurement Window Selection
 - Dynamic Power: measurement window starts at the beginning of input slope and extends to the end of vector buffer. This will include leakage power. As long as the leakage power is much smaller than dynamic power, the error can be tolerable. However for smaller processes, the leakage power will introduce large errors



Other's Measurement Window

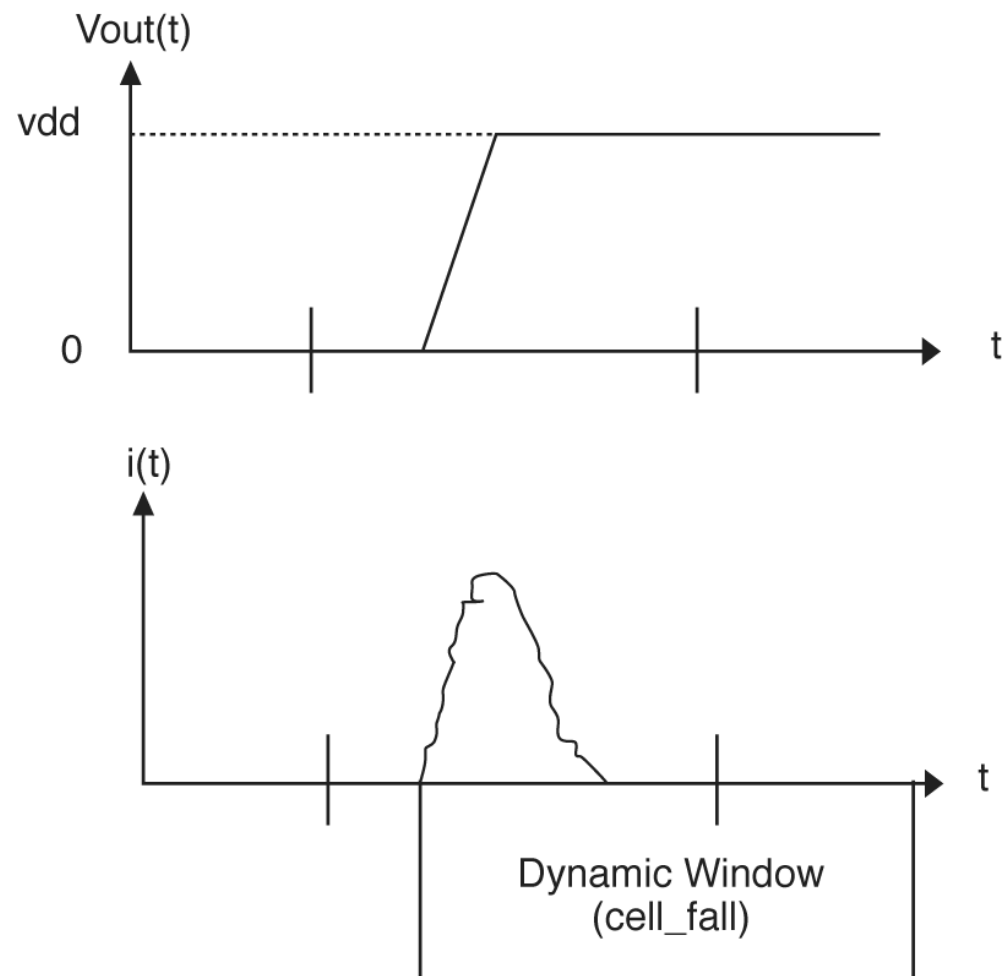



Other's Power Reports

- The internal power, or energy, is calculated for **EACH** transition as:

For rise_power

$$E_{int} = E_{tot} - C \cdot V_{dd}^2$$

For fall_power

$$E_{int} = E_{tot} - 0$$

- The sum of rise and fall power is very close to AccuCell's values. However, when multiple nodes are switching at the same time, instantaneous power will **NOT** be accurate with this method and does NOT match SPICE